

COVER PAGE

RZG2UL-OSM v1,1

OSM Size-L LGA Module, 45x45mm

Supported CPUs: RZ/G2UL, RZ/A3UL, RZ/FIVE

07/11/2023

SVN Revision: 2015

Variant: RZG2UL-Full

I2C USAGE AND ADDRESS TABLE

NAME	PERIPHERAL	ADDRESS
I2C0 1.8V	PMIC	$(0x12 \ll 1) + RW$
	GPIO Expander	$(0x20 \ll 1) + RW$
	OSM - CSI	
	OSM - I2C_A	
I2C1 1.8V	OSM - I2C_B	

DESIGN CONSIDERATIONS

DESIGN NOTE:
Example text for informational
design notes.

DESIGN NOTE:
Example text for critical
design notes.

LAYOUT NOTE:
Example text for critical
layout guidelines.

Fiducials



FIDUCIALS 3x TOP

FIDUCIALS 3x BOTTOM

Title: RZG2UL-OSM			Ronetix GmbH Hirschstetter Str. 19/Z110 1220 Vienna Austria		
Page: COVER PAGE					
Rev: 1.1	Date: 27/10/2023	Size: A3			
Sheet: 1 of 12	File: 01 Title Page.SchDoc				

eMMC, QSPI Flash

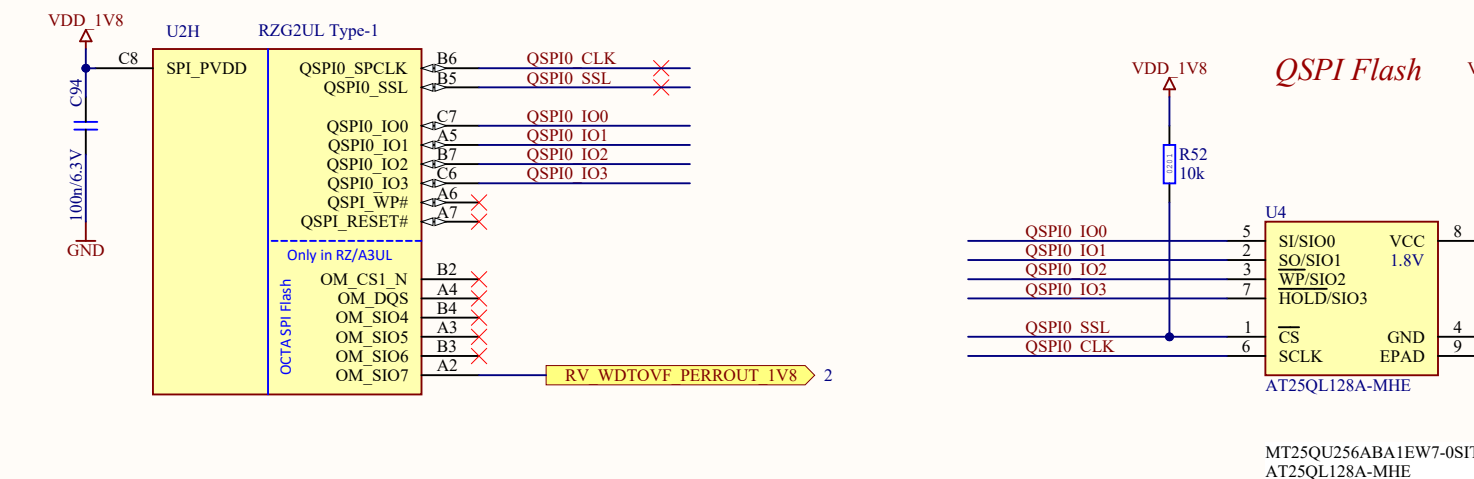
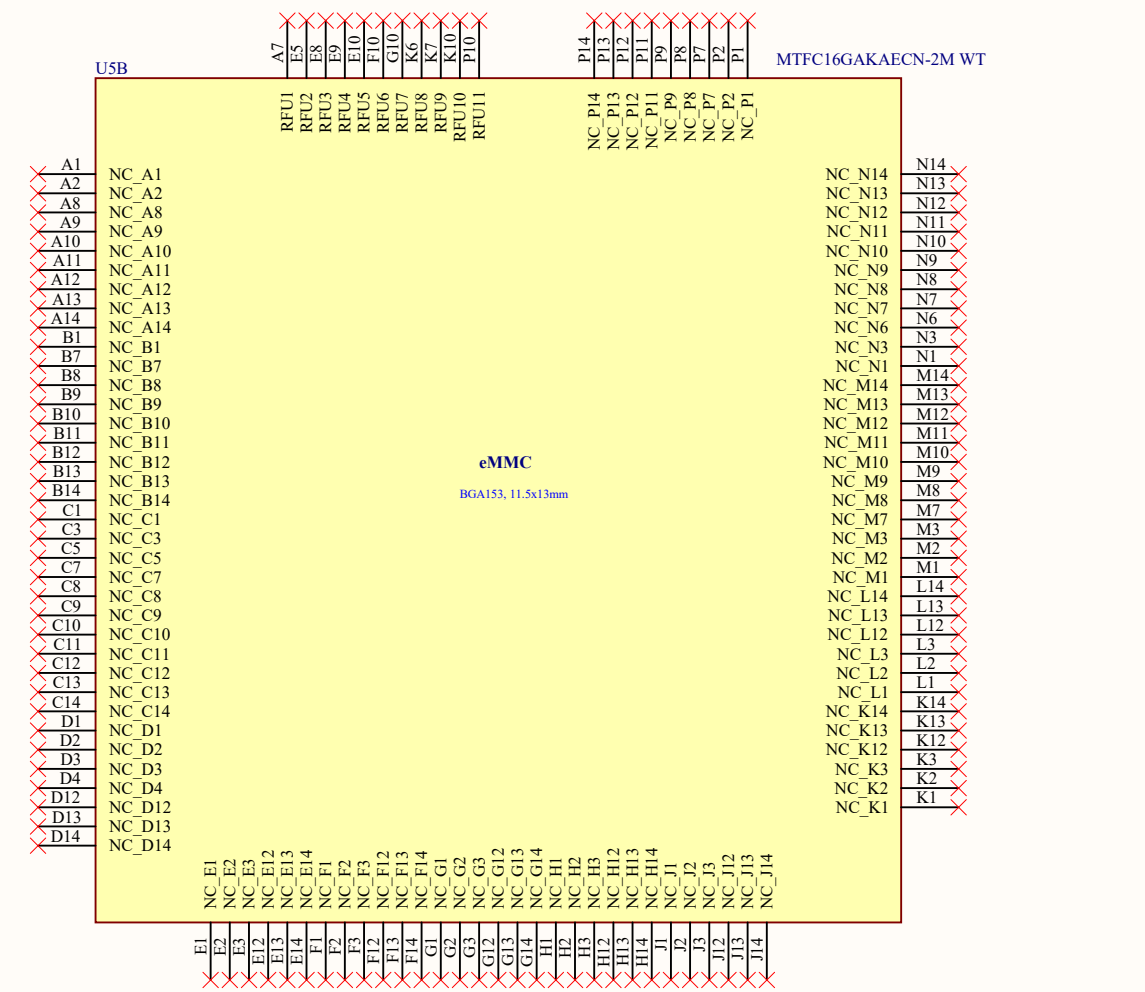
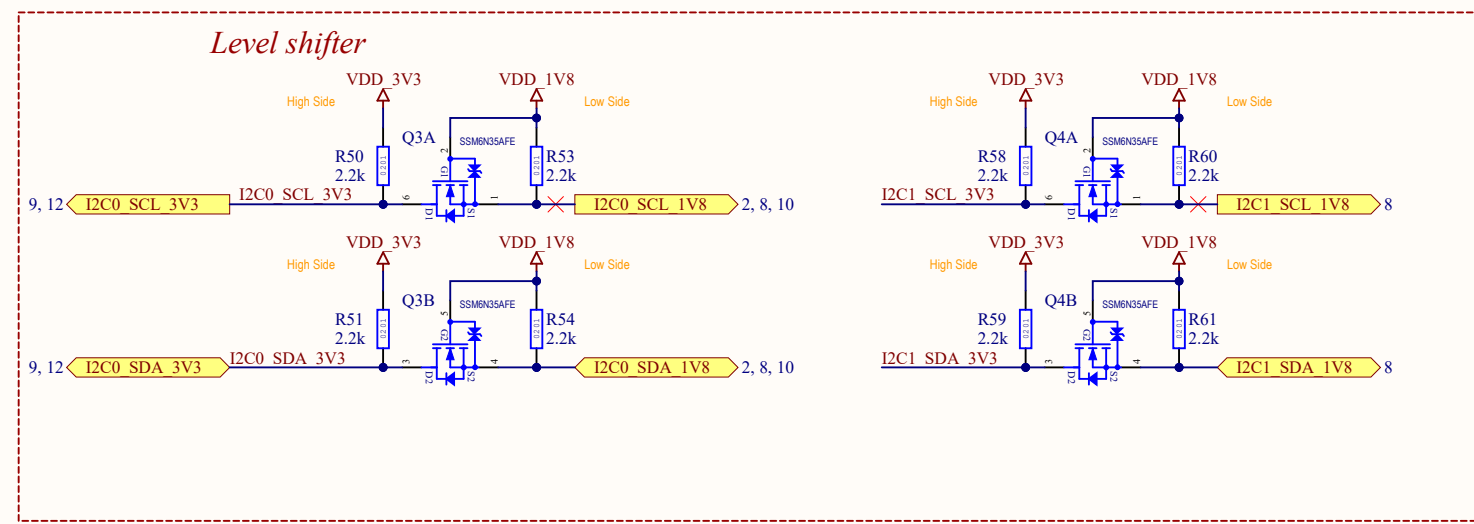
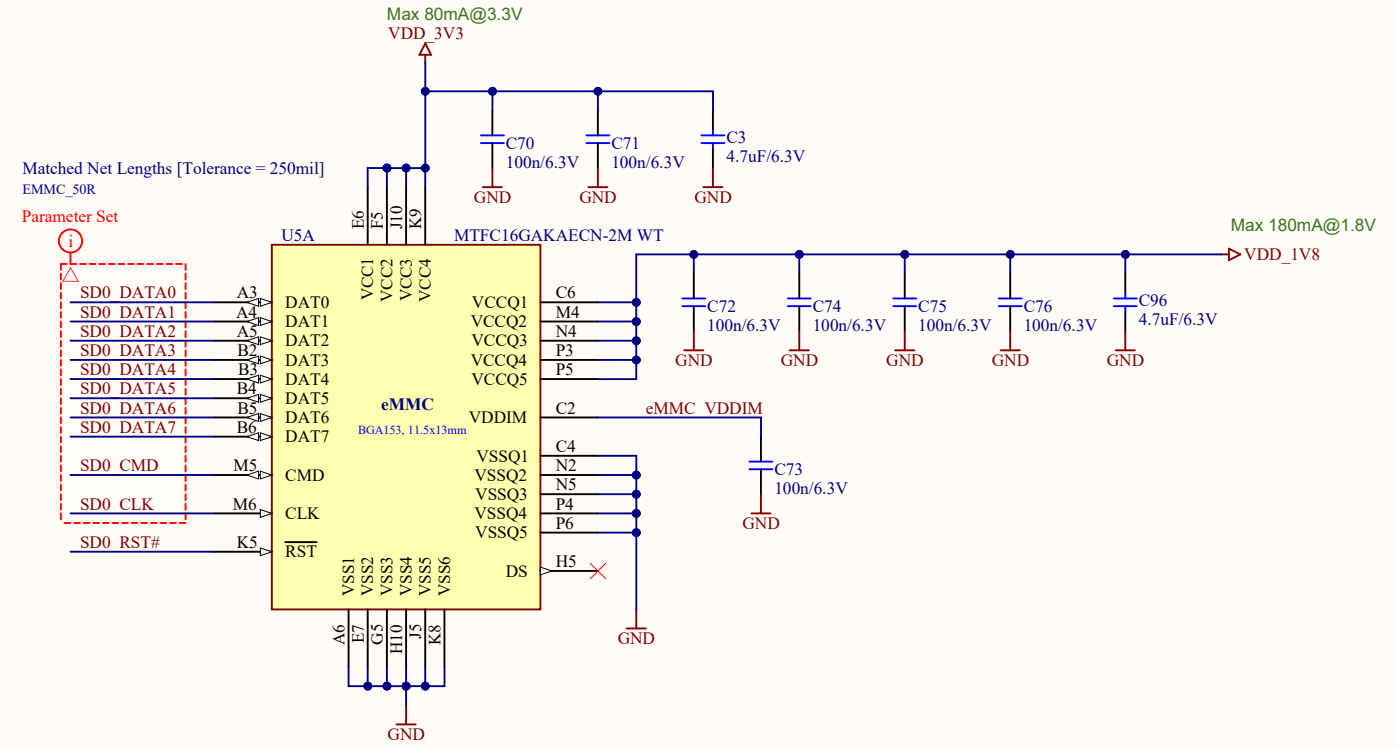
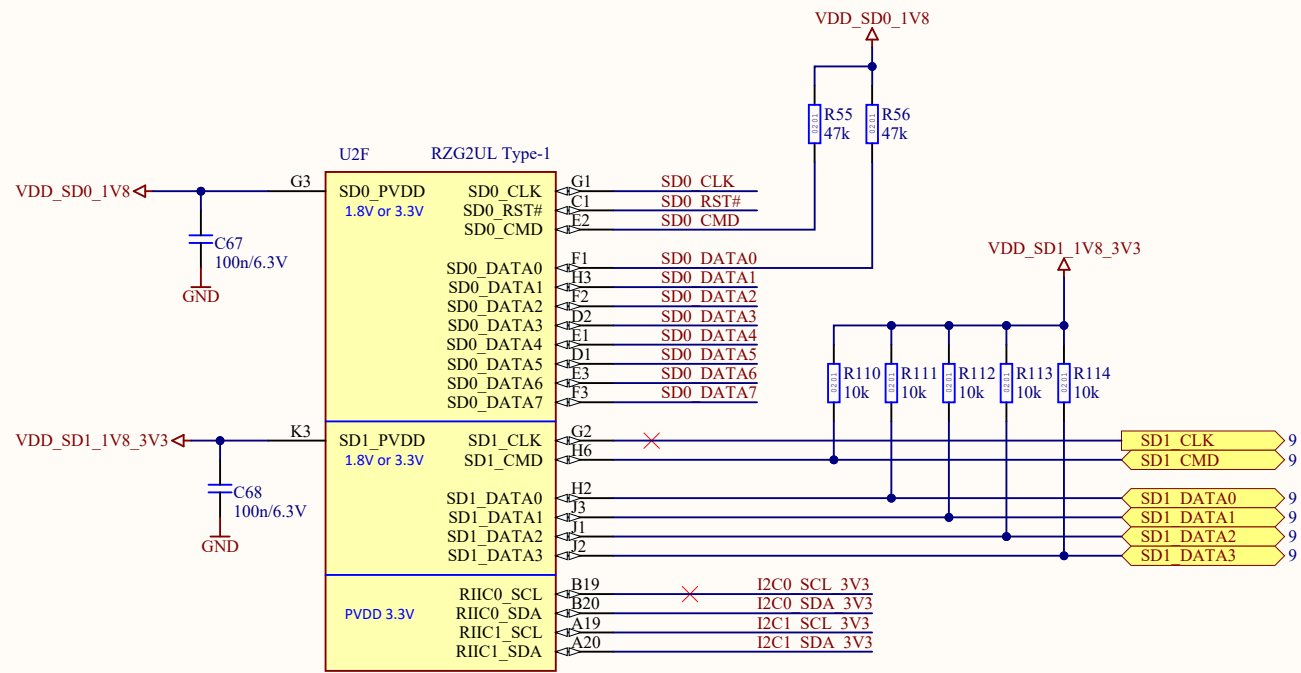

USB & LCD Display

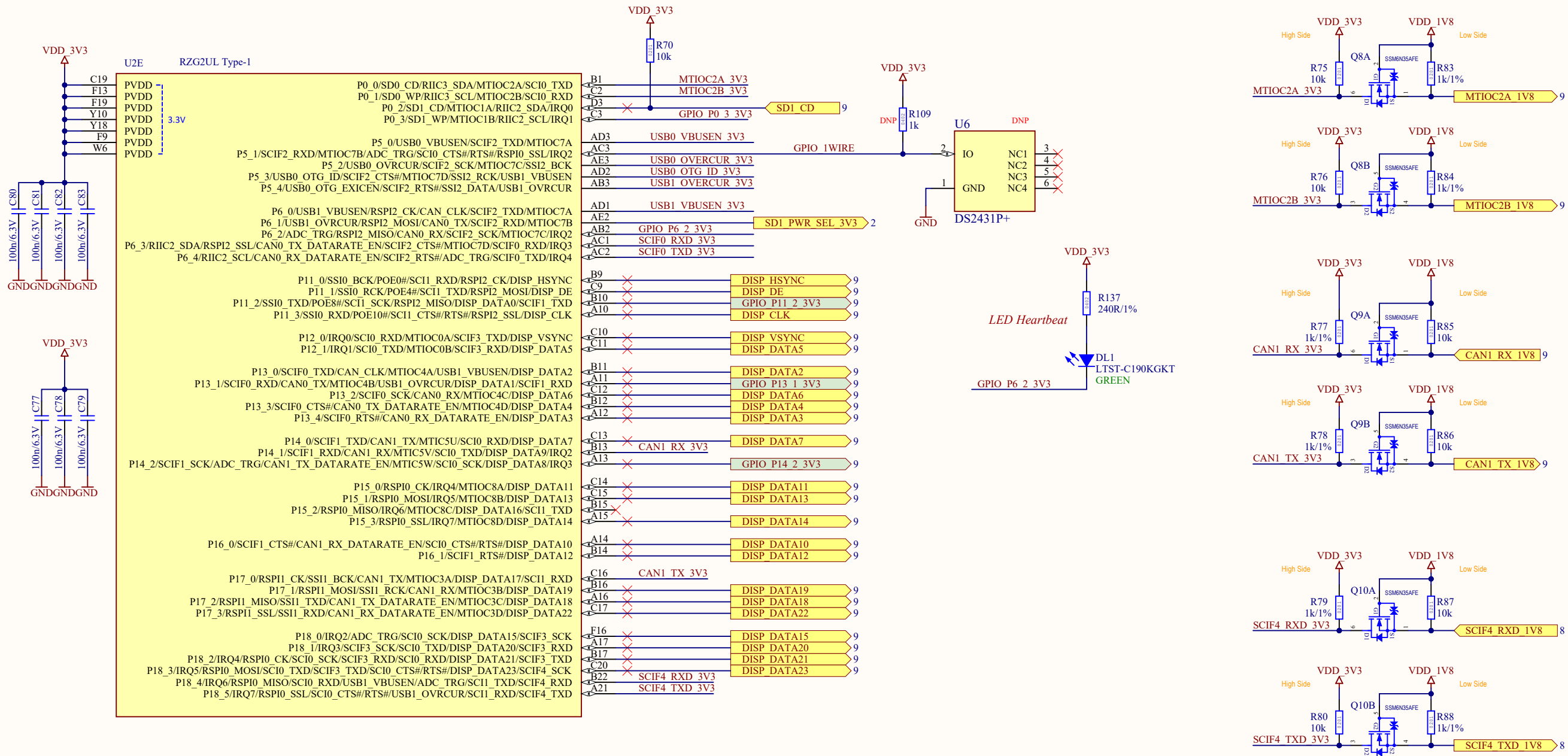

Bidirectional level translators for slow signals

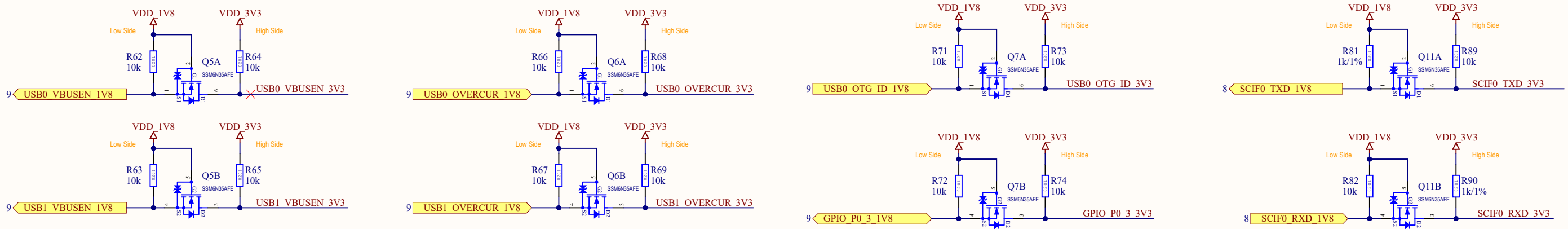

ETH, SPI and GPIO

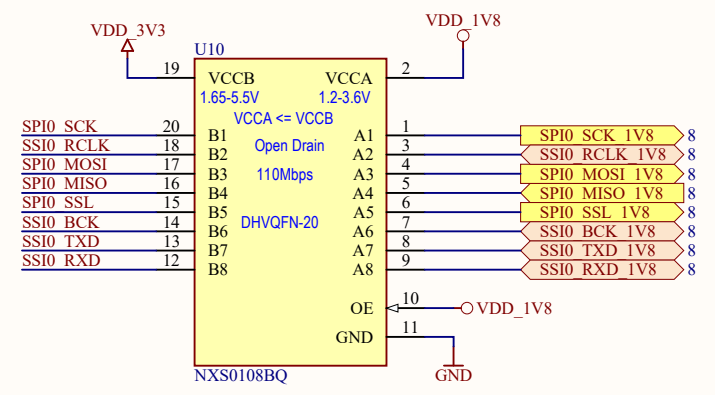
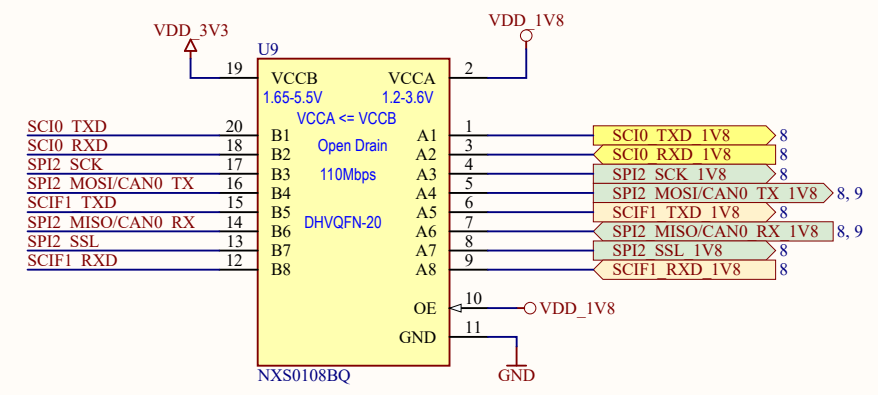
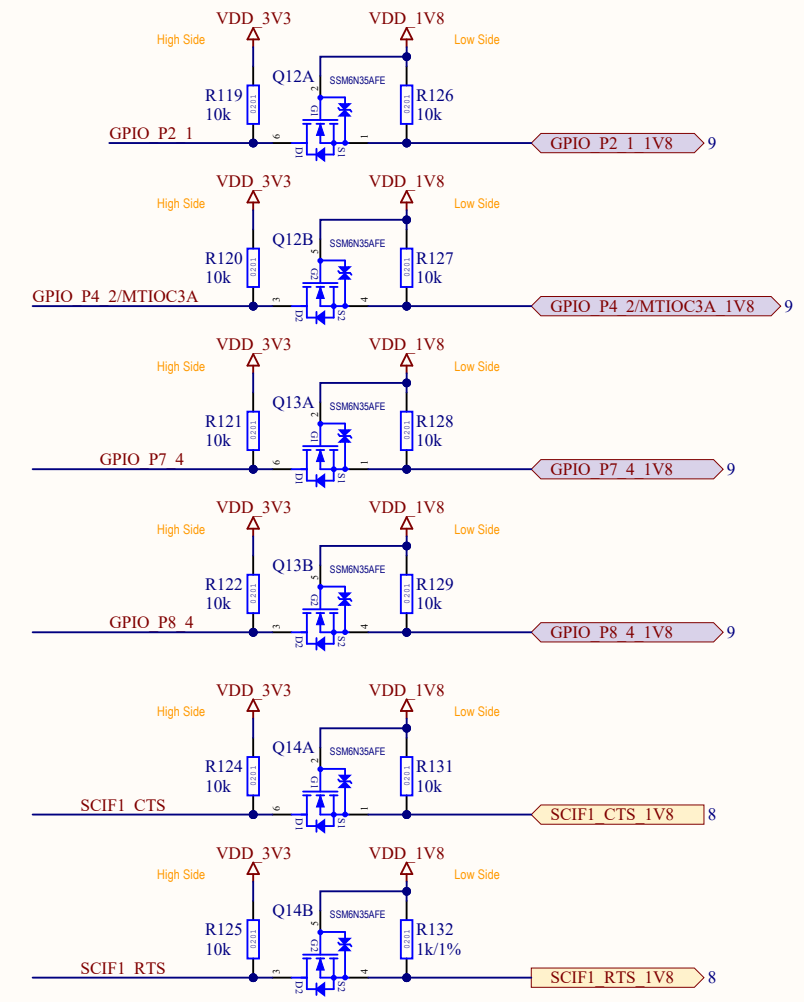
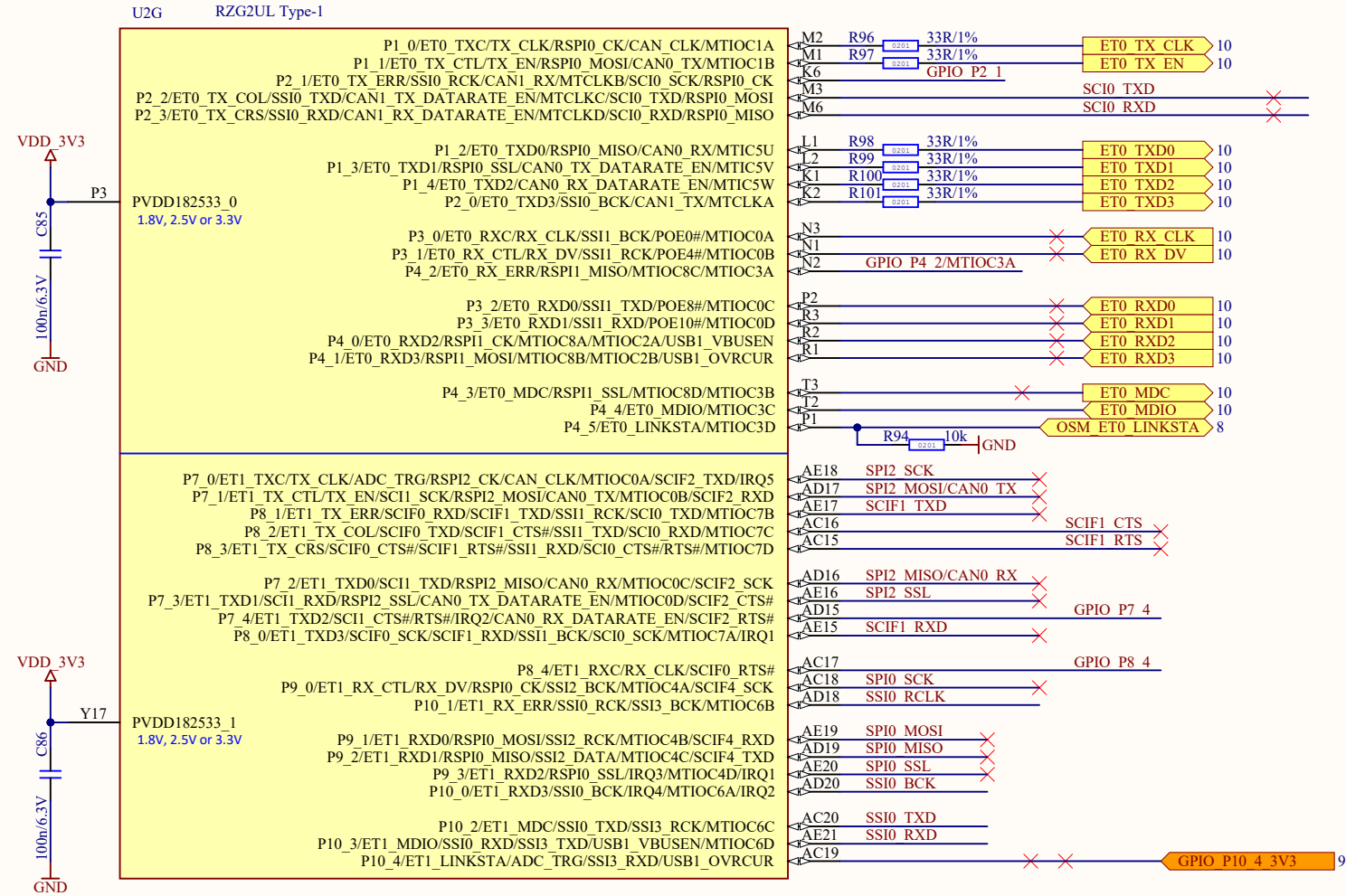

OSM - USB, GPIO, DISPLAY, SDIO

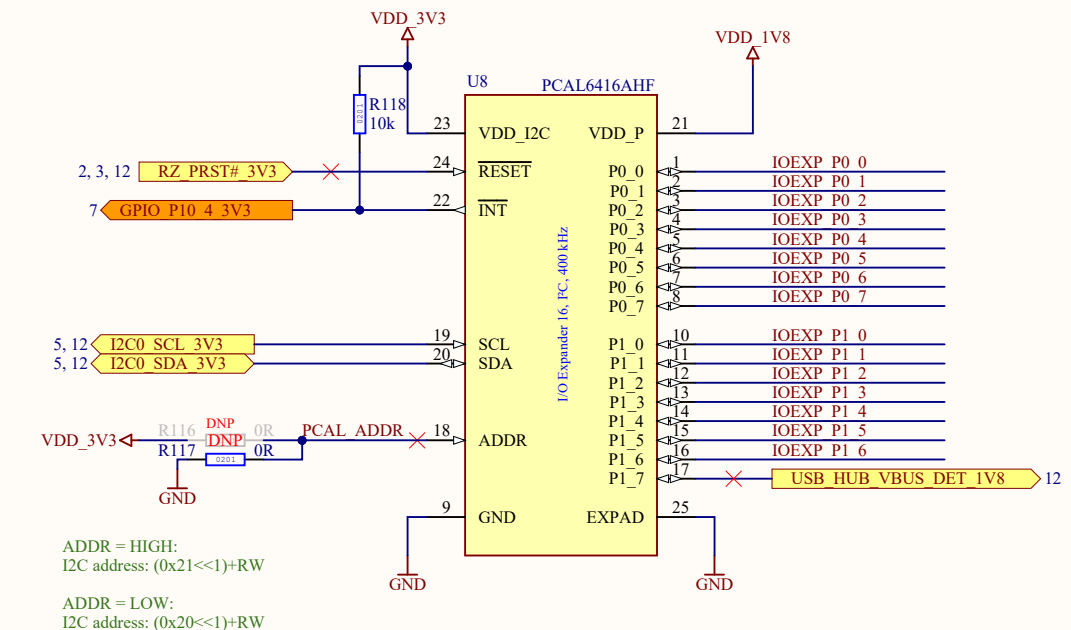
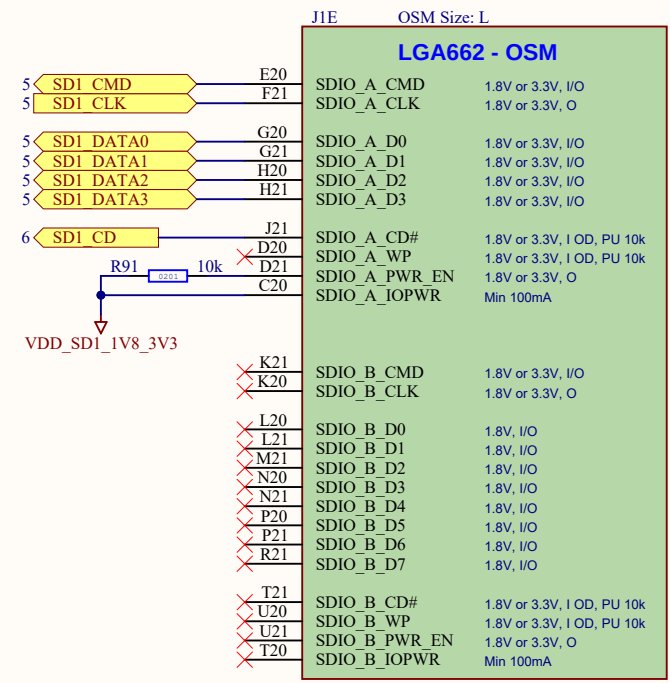
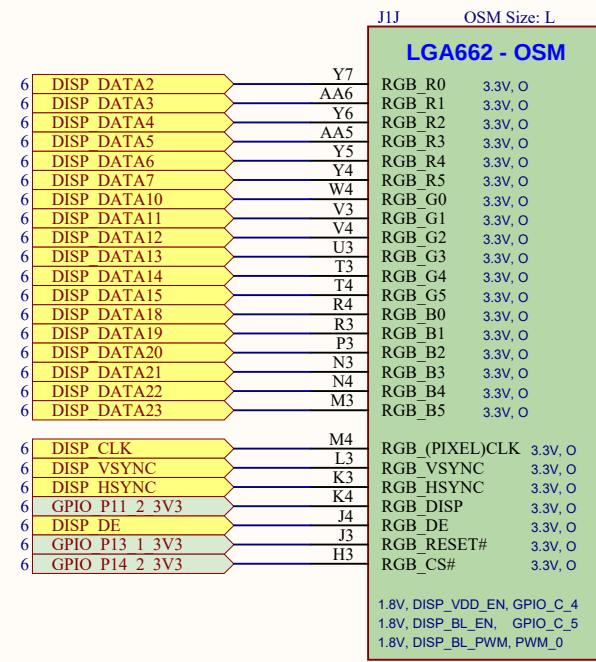
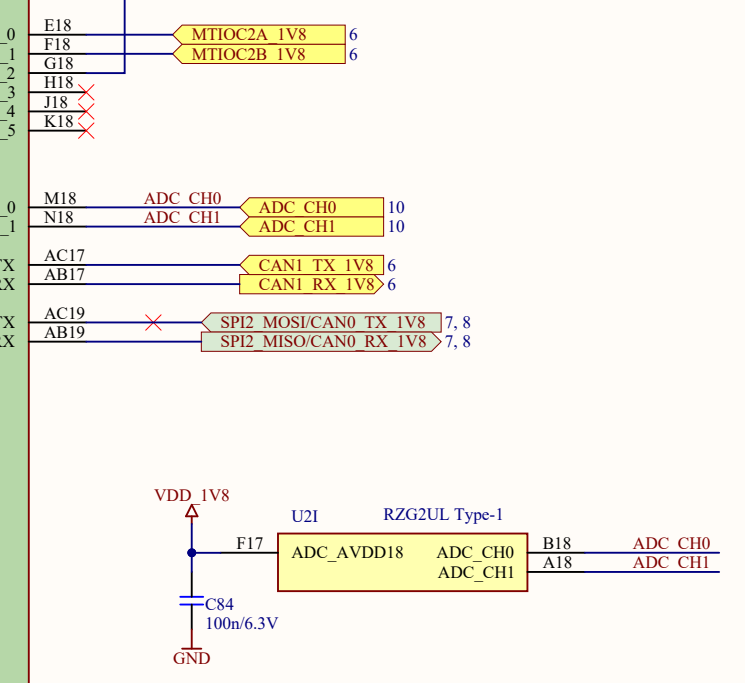
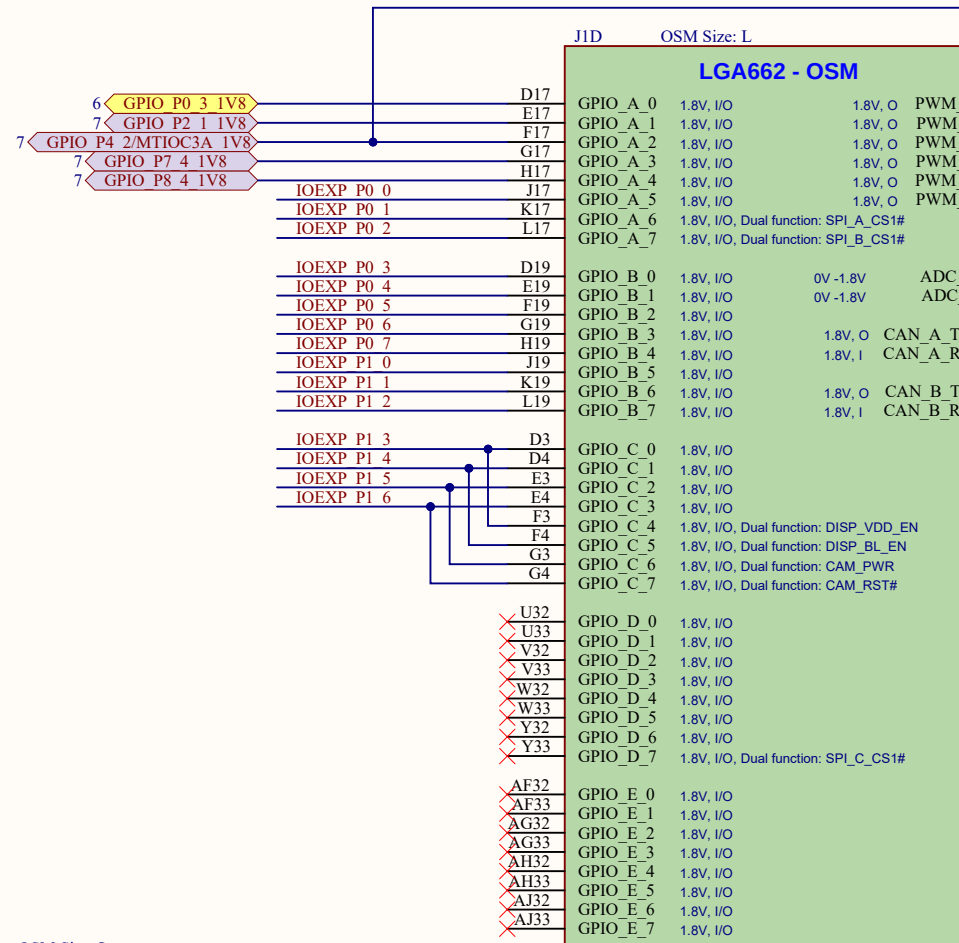
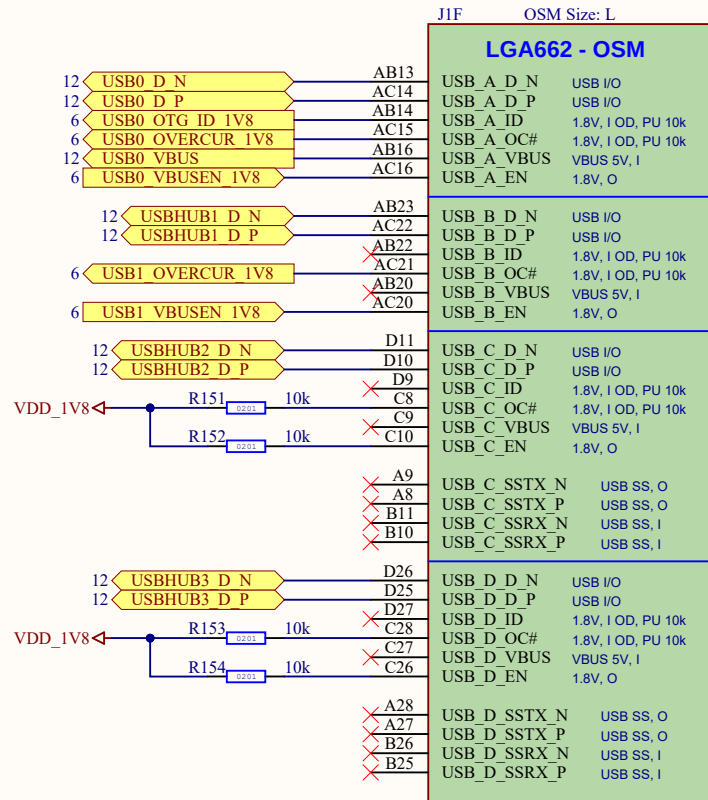

OSM - Ethernet, CSI

J1C OSM Size: L

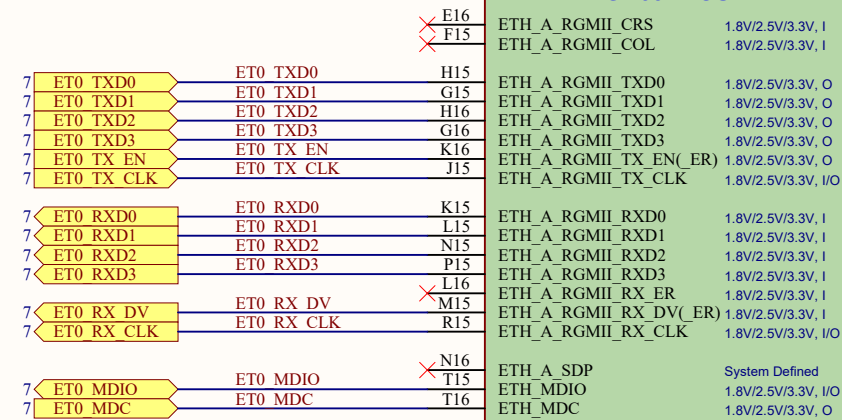

LGA662 - OSM		
ETH_A_RGMII_CRS	1.8V/2.5V/3.3V, I	
ETH_A_RGMII_COL	1.8V/2.5V/3.3V, I	
ETH_A_RGMII_TXD0	1.8V/2.5V/3.3V, O	
ETH_A_RGMII_TXD1	1.8V/2.5V/3.3V, O	
ETH_A_RGMII_TXD2	1.8V/2.5V/3.3V, O	
ETH_A_RGMII_TXD3	1.8V/2.5V/3.3V, O	
ETH_A_RGMII_TX_EN(ER)	1.8V/2.5V/3.3V, O	
ETH_A_RGMII_TX_CLK	1.8V/2.5V/3.3V, I/O	
ETH_A_RGMII_RXD0	1.8V/2.5V/3.3V, I	
ETH_A_RGMII_RXD1	1.8V/2.5V/3.3V, I	
ETH_A_RGMII_RXD2	1.8V/2.5V/3.3V, I	
ETH_A_RGMII_RXD3	1.8V/2.5V/3.3V, I	
ETH_A_RGMII_RX_ER	1.8V/2.5V/3.3V, I	
ETH_A_RGMII_RX_DV(ER)	1.8V/2.5V/3.3V, I	
ETH_A_RGMII_RX_CLK	1.8V/2.5V/3.3V, I/O	
ETH_A_SDP	System Defined	
ETH_MDIO	1.8V/2.5V/3.3V, I/O	
ETH_MDC	1.8V/2.5V/3.3V, O	

LAYOUT NOTE:

RGMII Routing Constraints (Reduced Gigabit Media Independent Interface):

The RGMII signals must be length-matched by TX and RX groups. That is, the TX group should be matched within 0.25 inch (6.35 mm), and the RX group should be matched within 0.25 inch (6.35 mm). Total length should not exceed 1.75 inch (44.5 mm). There is no requirement to match the TX and RX groups because their clocks are not related.

Parameter Set ClassName: ENET_RGMGII_TX_50R
Matched Net Lengths [Tolerance = 250mil]
Length Constraint [Min Length = 0mil Max Length = 1750mil]

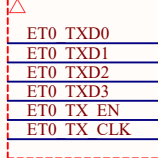

Parameter Set ClassName: ENET_RGMGII_RX_50R
Matched Net Lengths [Tolerance = 250mil]
Length Constraint [Min Length = 0mil Max Length = 1750mil]

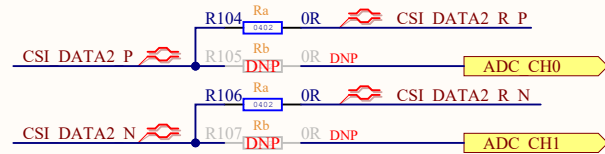
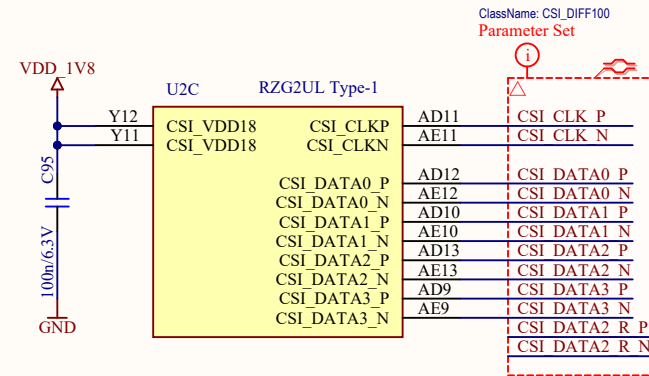
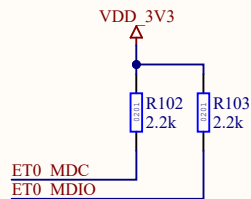
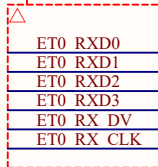

J1I OSM Size: L

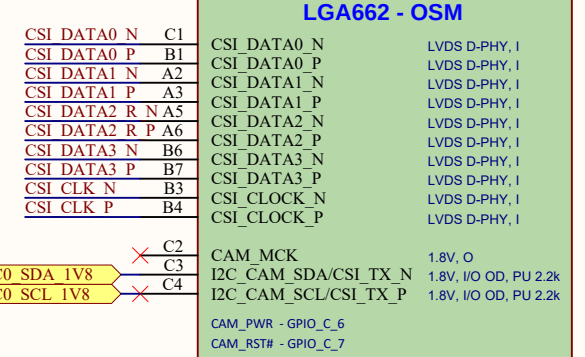

USB 4-Port Hub

